

INSTA-VALVE 250 PATRIOT

4" - 12" HEAVY DUTY INSERTION VALVE Patents Pending

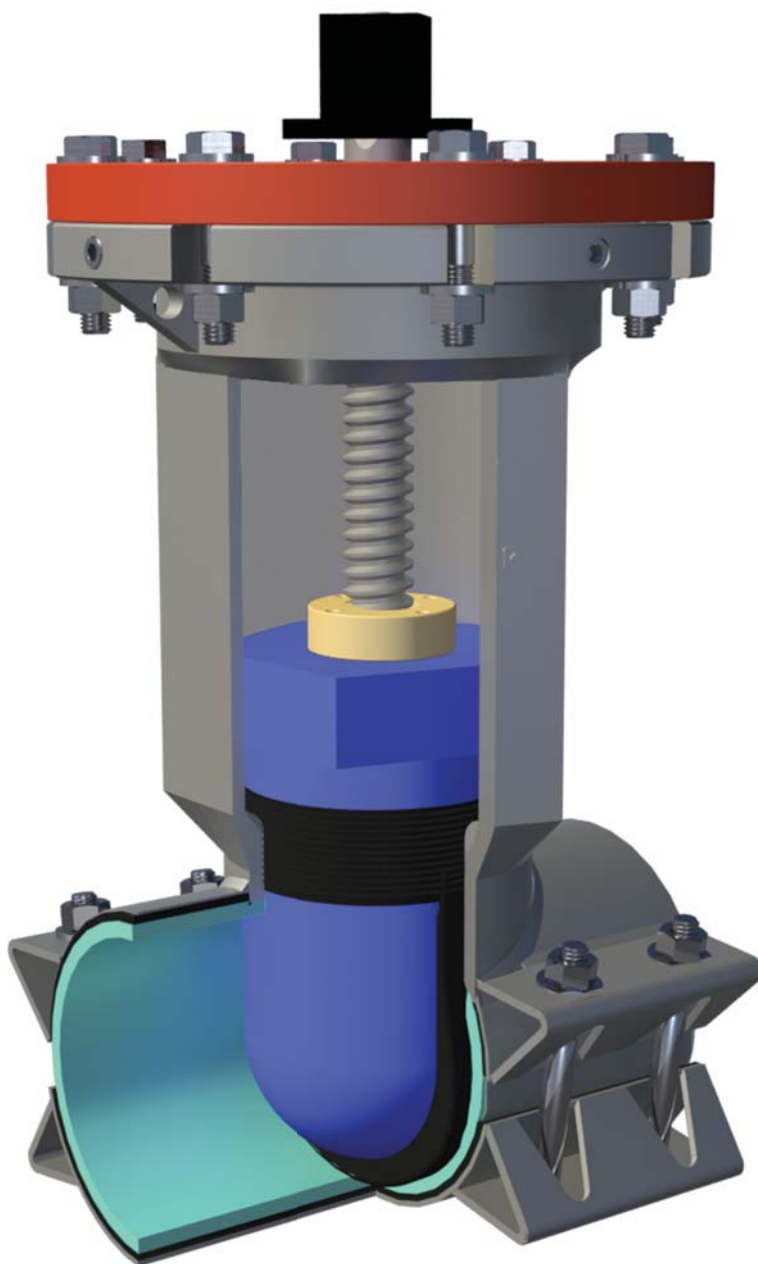



 **HYDRA-STOP**[®]
SOLUTIONS FOR CONTROL

10 Reasons to Specify Hydra-Stop

Hydra-Stop Feature	Points of Difference to Competitors	Customer Benefit
250 PSI	250 PSI working pressure.	Increased Installation Opportunities
Stainless Steel Construction	Improved corrosion resistance.	Quality Assurance and Increased Installation Opportunities
Made in USA *	Meets American Iron and Steel Requirement (Public Law 113-76) and fulfills requirements specified in additional "Buy American" legislation. Meets "Made in USA" and "Buy America" requirements with the additional purchase of stainless steel domestic hardware.	Increased Installation Opportunities, Improved Delivery and Quality Assurance
NSF 61 / NSF 372	The IV 250 is NSF/ANSI Standard 61 and NSF/ANSI Standard 372 to meet the regulatory requirements for the U.S. and Canada assuring safe use in drinking water systems.	Increased Installation Opportunities and Quality Assurance
Factory Pressure Tested	Each IV 250 is pressure tested and serialized for traceability before leaving our manufacturing facility.	Quality Assurance, Trouble Free Installation and Emergency Management
Qualifies for Hydra-Ship	Same day shipping on qualifying products if ordered by 12:00 PM Central Time.	Increased Installation Opportunities, Inventory Reduction and Emergency Management
IV 250 Valve Cartridge	Engineered to install faster, reduce operating torque and simplify installation procedures. Reinforced composite polymer provides increased strength and corrosion protection.	Reduced Installation Time, Trouble Free Installation, and Warranty Protection
Reinforced Resilient Wedge Seal	IV 250 reinforced wedge seal is designed to withstand 250 psi operation.	Increased Installation opportunities, trouble free operation
Multiple Installation Options	IV 250 can be installed on AC, CI, DI and PVC pipes in any orientation.	Reduced Installation Time, Trouble Free Installation
Access to Hydra-Stop Training and Technical Support	Hydra-Stop, with over 30 years of experience, is the only manufacturer who produces insertion valve, insertion valve installation equipment and commands the technical expertise and experience to completely support your installation procedure.	Trouble Free Installation, Warranty Protection and Quality Assurance

Compare for Yourself

When specifying your next insertion valve, the **Insta-Valve 250 Patriot Insertion Valve** will be at the top of your list. The Insta-Valve 250 Patriot is the **ONLY** insertion valve which offers **ALL** of the following features as standard.

Hydra-Stop Feature	Insta-Valve 250 Patriot	Competition
250 PSI		
Stainless Steel Construction		
Made in USA*		
NSF 61 / NSF 372		
Factory Pressure Tested		
Qualifies for Hydra-Ship		
IV 250 Valve Cartridge		
Reinforced Resilient Wedge Seal		
Multiple Installation Options		
Access to Hydra-Stop Training and Technical Support		

*With the additional purchase of stainless steel domestic hardware.

Insta-Valve 250 Patriot™ Materials

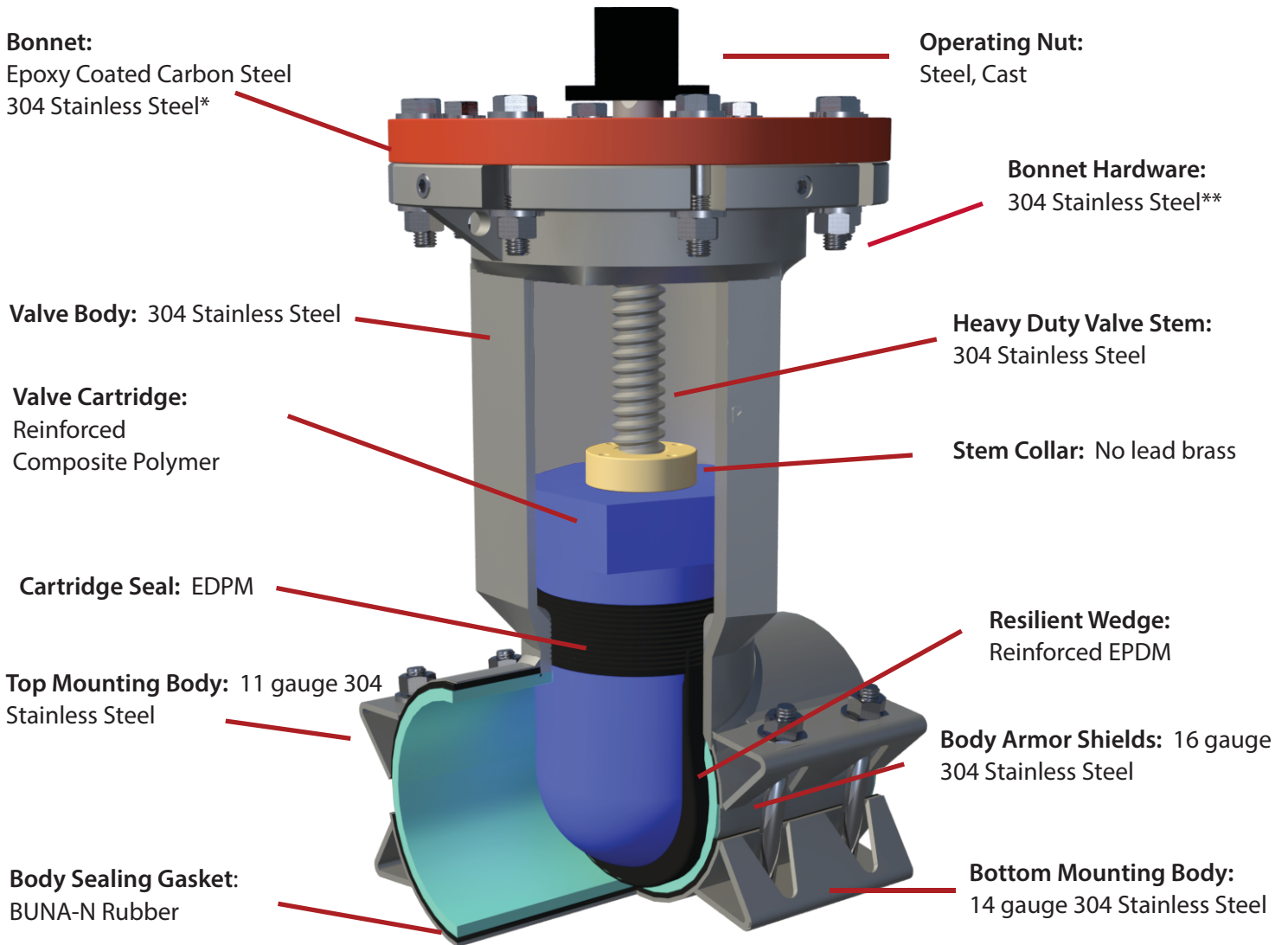

The difference is inside...

The IV 250 is engineered to install faster, reduce operating torque and simplify installation procedures.

The IV 250 valve cartridge constructed of reinforced composite polymer provides increased strength and corrosion protection ensuring reliable operation and performance.

The reinforced wedge seal is engineered to withstand 250 psi operation and the cartridge seal is designed to seal on an engineered sealing surface within the valve body. These features ensure superior performance over other available insertion valve technologies.

Patriot Series: Made in USA

The IV 250 Patriot Insertion Valve is manufactured in the USA. Meets American Iron and Steel Requirement (Public Law 113-76) and fulfills requirements specified in additional "Buy American" legislation. Meets "Made in USA" and "Buy America" requirements with the additional purchase of stainless steel domestic hardware.

When the project calls for meeting AIS requirements, specify the Insta-Valve 250 Patriot.



*Domestic Stainless Steel Bonnet available at additional cost.

** Domestic Stainless Steel Hardware available at additional cost.

The Hydra-Stop System

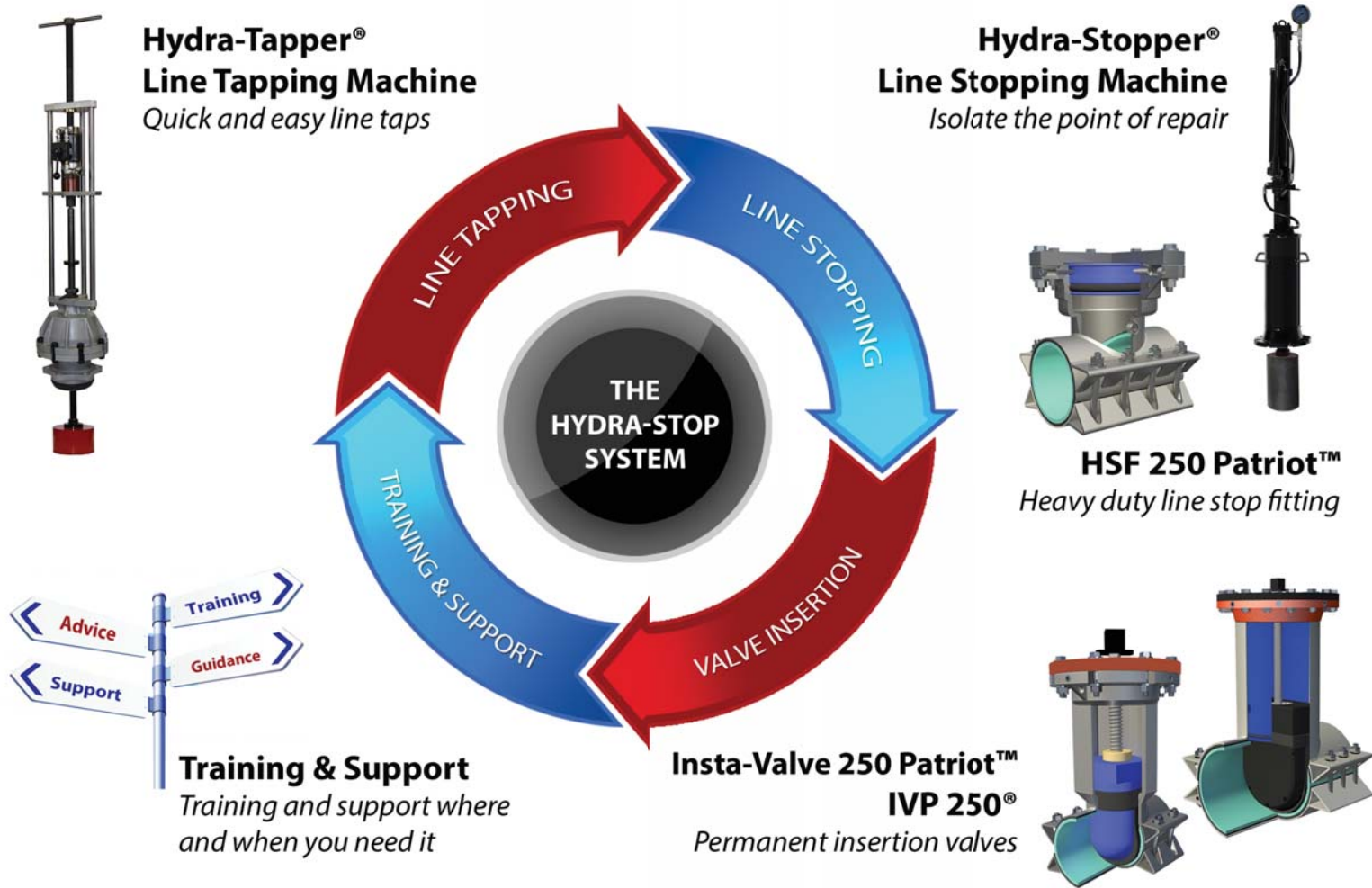

Why Specify the Hydra-Stop System

- The only complete and integrated tapping, stopping and valve insertion system which allows under pressure pipe maintenance and repair on water, wastewater and other fluid systems without interrupting service or requiring system shutdown.
- Available expansion kits allow system to expand in scale and function reducing the capital equipment investment of end users by 30%.
- Over 30 years of industry leading experience in engineering, manufacturing and training and support ensure trouble free operations from project planning to completion.

HYDRA-STOP®
SOLUTIONS FOR CONTROL

144 Tower Drive, Suite A, Burr Ridge, IL 60527
Phone: 708-389-5111 Fax: 708-389-5125
Toll Free: 1-800-538-7867

Visit us on the Web at www.hydra-stop.com

Prices and Specifications subject to change without notice. Patents Pending