

REV	BY	DATE	DESCRIPTION
---	---	---	---

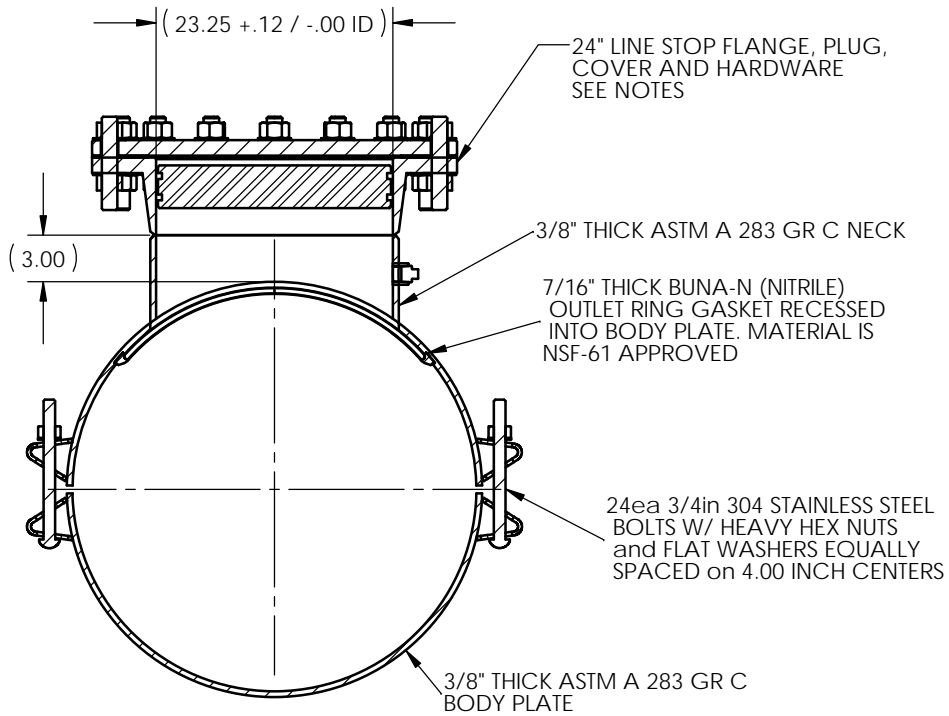

**SECTION A-A**

LINESTOP FLANGE = ANSI B16.5 CLASS 150 WELDNECK  
 LINESTOP PLUG = ASTM A36  
 COVER = AWWA C207 CLASS D BLIND  
 COVER HDW = ALLOY STEEL  
 O-RING = BUNA-N

NOTE:  
 1) MAWP = 150PSI  
 2) MATP = 225 PSI  
 3) FITTING MANUFACTURED TO AWWA C223.  
 4) FINISH = FUSION BONDED EPOXY

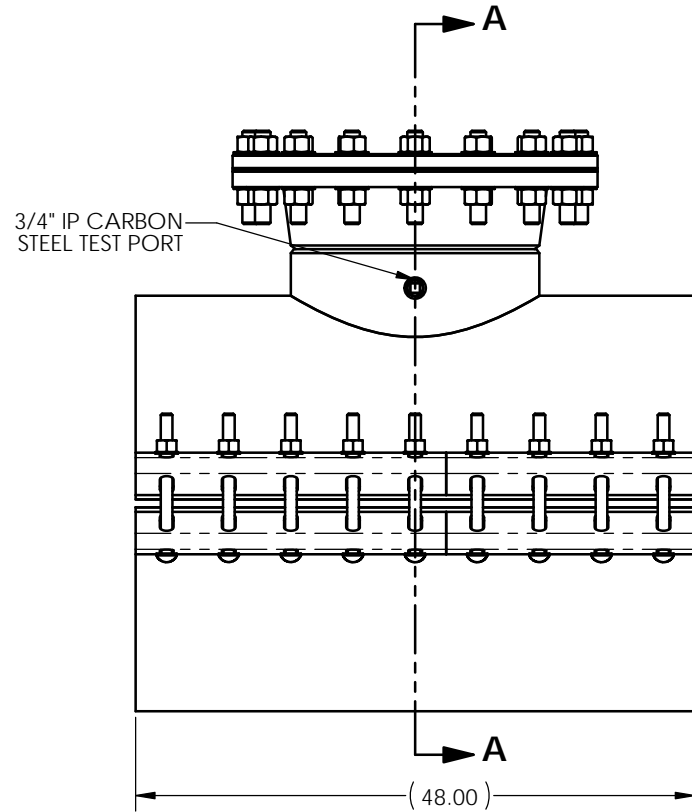

**TOP VIEW**

TOLERANCES U.N.O. XX = ±.06 XXX = ±.015 FRACTIONS = ANGLES = ±1° MACH. FIN. =	NOTES: REMOVE BURRS AND SHARP EDGES DO NOT SCALE DWG.	APP'D	DATE
	SCALE: 1:8	CK'D	DATE
ALL DIMENSIONS ARE IN INCHES.	DRN	PRS	DATE 2/4/20
TITLE <h3 style="text-align: center;">30" LINESTOP</h3> <p style="text-align: center;">31.80"-32.20" RANGE</p>			
SMITH-BLAIR P/N		RPPCS32002424B	
DWG. NO.		SK-1 2-4-20	1 OF 1 SHEET --- REV.